

UT15B/C

Operating Manual



Multifunction Voltage Testers

1) Introduction

Notice:
Please open battery cover and remove anti-leakage piece before using. (Refer to content 3:instrument layout 13)

Thank you for purchasing a voltage tester. This tester has been designed in accordance with the latest international safety standards. The combivolt testers are fully automatic voltage indicators capable of measuring AC/DC voltage up to 690 V. Both units have visual and acoustic continuity indication.

Constructed in accordance with IEC 61010-1 and IEC 61243-3.

- Single pole phase indication
- 2 pole phase rotation indication
- LED & LCD display (UT15C)

2) Safety notices

This manual contains information that must be followed for operating the meter safely and maintaining the meter in a safe operating condition. If this meter is not used in the manner specified, the protection provided may be impaired.

⚠ Warning! Warns of potential, refer to the instruction manual to avoid personal injury or damage to the meter.

⚠ Caution! Dangerous voltage. Danger of electrical shock

⚠ Perfect display is only guaranteed within a temperature range of -10~50 C, relative humidity < 85%.

⚠ A statement about protection impairment if used in a manner not specified by the manufacturer.

The voltage detectors are designed to be used by skilled persons and in accordance with safe methods of work.

The voltages marked on the voltage detector are nominal voltages and the voltage detector is only to be used on installations with the specified nominal voltages.

The different indicating signals of the voltage detector are not to be used for measuring purposes.

Before using a voltage detector at locations with a high background noise level, it has to be determined whether the audible signal is perceptible.

It is importance to check the state of the battery before use and to replace it if necessary.

☑ Continuous double or reinforced insulation complies with IEC 536, class 11

⚡ Suitable for live working

CONFORMS TO UL STD 61010-1, 61010-2-030, 61010-031
CERTIFIED TO CSA STD C22.2 NO.61010-1, 61010-2-030 and 61010-031

CAT IV: Applicable to test and measuring circuits connected at the source of the building's low-voltage MAINS installation.

CE Symbol of conformity, confirms conformity with relevant EU directives. The meter complies with EMC directives (2004/108/EC), the Low Voltage Directive (2006/95/EC) described in the standard EN 61010-1, 61243-3.

The meter has been designed in accordance with the safety regulations for electronic measuring instruments, EN 61010-1:2010, EN 61010-2-033:2010, EN 61010-031:2002+A1:2008, IEC 61243-3:2009, EN 61243-3:2010, EN 61326-1.

Voltages above 75V DC or 50V AC may constitute a serious shock hazard.

Before using the meter check for physical damage to the casing in particular around the connectors. If the case is damaged do not use the meter.

Check the test probes for damaged insulation or exposed metal. Check the leads for continuity.

Do not apply more than the rated voltage, as marked on the meter between the terminals or between any terminal and ground.

Do not use or store the meter in an environment of high temperature, humidity, fumes, vapour, gaseous, inflammable and strong magnetic field. The performance and safety of the instrument and the user may be compromised in such circumstances.

Disconnect circuit power and discharge all high voltage capacitors before testing resistance, continuity and diodes.

Remove the batteries if the meter is not in use for a long period. Constantly check the battery as it may have leaked. A leaking battery will damage the meter.

The meter may only be opened by a qualified service technician for calibration and repair

3) Instrument Layout

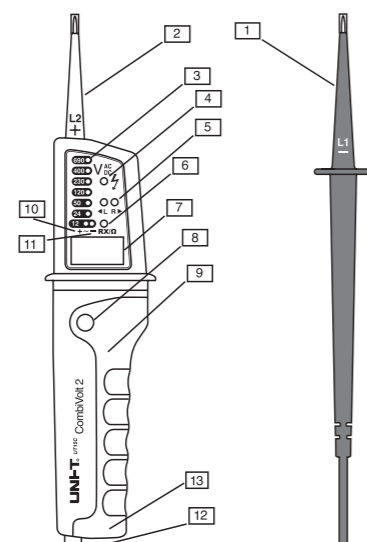

- 1) Test Probe (-) L1
- 2) Test Probe (+) L2
- 3) LED's for voltage indication
- 4) LED for single - pole test
- 5) Right & Left LED, phase rotation indication
- 6) LED for continuity
- 7) LCD for voltage display (only UT15C)
- 8) Contact electrode for double-pole test of phase rotation and single-pole test
- 9) Torch button on the back
- 10) Positive LED
- 11) Negative LED
- 12) Battery Compartment
- 13) Anti-leakage piece

Carrying out measurements

Perform a self test of the unit. Connect the two test probes L1 and L2. The continuity LED (6) will be lit and an audible tone should be heard.

Before any test check the unit on a known voltage source.

If the unit is defective it should be put out of service and returned to uni-trend for repair.

4) Voltage test

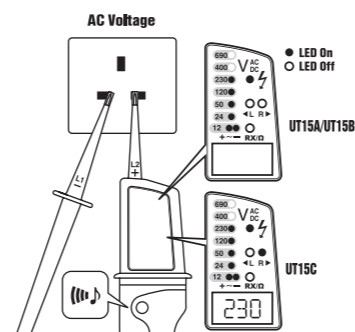

Always hold the test probes by the handles behind the finger guards. Observe the safety notices at all times.

An audible tone is present when an AC voltage and a negative DC voltage are indicated.

The maximum switch on time is 30 s. When this time has elapsed you must wait 10 minutes before retesting.

Connect probes to voltage source observing polarity of the test probes L2 is positive probe, L1 is the negative probe.

For AC voltage the value is indicated on the LEDs (3) and on the LCD display (UT15C only). The + and - LEDs are illuminated and buzzer is audible.

For DC voltage connect probe L2 to the positive terminal and L1 to the negative terminal. The voltage is displayed on the LEDs and the LCD display (UT15C only). The positive LED (10) is illuminated. If the polarity is reversed the buzzer will sound. The negative LED (11) will be illuminated.

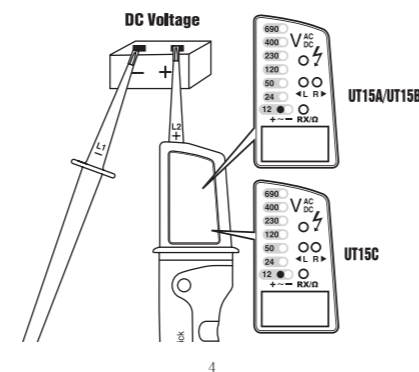

5) Single pole voltage detection

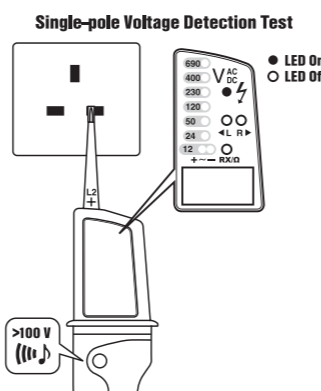

Perform a function test prior to this test.

This unit can be used as a single pole voltage detector when batteries are inserted.

The single pole test is intended only as a quick check. The circuit must be checked again for the presence of voltage using the two pole method.

Connect test probe L2 to the voltage source and keep finger on the contact electrode (8). If an AC voltage above 100 V is present the LED (4) is illuminated and the buzzer sounds.

The single pole test can be negatively affected by unfavourable conditions such as electrostatic field, good insulation etc.

6) Continuity test

The continuity test is only possible when batteries are inserted and in good condition.

Ensure the circuit under test is not live.

Connect test probes L1 and L2 to the circuit. The continuity LED (6) will illuminate and the buzzer will sound.

The unit indicate continuity below 400 Kohm

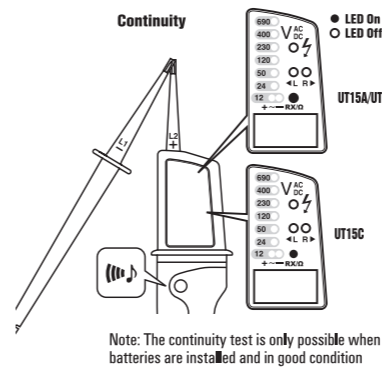

7) Phase rotation test

Perform a function test prior to this test.

This unit can determine the phase rotation within a three phase supply.

Connect test probe L2 to the supposed phase 2 and the test probe L1 to the supposed phase 1. If the R LED illuminates the phases are in the correct sequence 1 to 2.

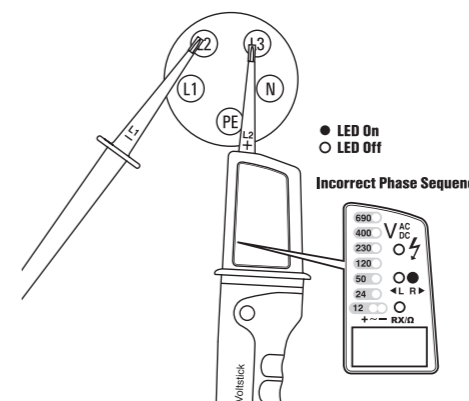
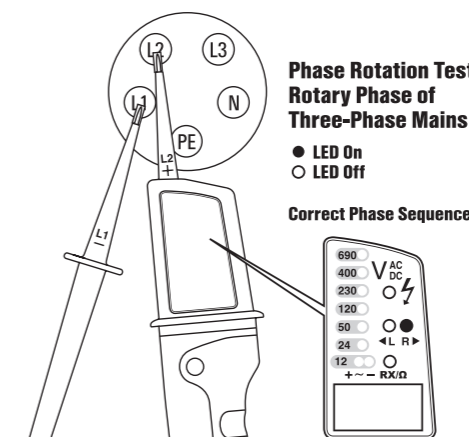

Connect test probe L2 to the supposed phase 3 and test probe L1 to the supposed phase 2. If the R LED illuminates the phases are in the correct sequence 2 to 3. Connect test probe L2 to the supposed phase 1 and the test probe L1 to the supposed phase 3. If the R LED illuminates the phases are in the correct sequence 3 to 1.

During phase rotation test touch the contact electrode.

If the L LED illuminates then the phase sequence is anti clockwise.

8) Maintenance

Do not attempt to repair this unit. There are no user serviceable items in this unit. Never attempt to open the casing apart from the battery cover.

Do not use the instrument if there is any physical damage to the case or test leads.

The outside of the unit can be cleaned with a soft damp cloth only. Do not use abrasive or chemical cleaning agents.

Changing batteries

Turn the battery cover by 90 degrees anti clockwise. Remove the cover and take out spent batteries. Replace with 2 off 1.5V AAA (LR03) batteries, checking the correct polarity.

Replace the battery cover and turn by 90° clockwise.

Spent batteries should be disposed of responsibly and with compliance with current recycling and disposal regulations.

Calibration

The recommended calibration interval for the UT15A/UT15B/UT15C is 12 months.

9) Specifications

Voltage	UT15A/UT15B	UT15C
Voltage display	12 - 690 V AC/DC	12 - 690 V AC/DC
LED Resolution	12,24,50,120,230	12,24,50,120,230
	400,690	400,690
LCD Resolution		(12-690V AC/DC) +/- 3% + 8 digits
Voltage detection	automatic	automatic
Acoustic signal	AC voltage - DC voltage	AC voltage - DC voltage
Polarity detection	Full range	Full range
Response time	LED < 0.1s	LED < 0.1s, LCD < 2s
Frequency range	0 - 400 Hz	0 - 400 Hz
Peak Current	Is < 0.3A/is(after 5s)	Is < 0.3A/is(after 5s)
	<3.5mA	<3.5mA
Operation time	30s	30s
Recovery time	10 min	10 min
Auto power on	<12 V AC/DC	<12 V AC/DC

Single pole

voltage indication

Voltage range	100 - 690 V AC	100 - 690 V AC
Frequency range	50 - 400 Hz	50 - 400 Hz

Continuity

Measuring range	0 - 400 Kohm	0 - 400 Kohm
-----------------	--------------	--------------

Phase rotation test

Voltage range	100 - 690 V	100 - 690 V
Frequency	45 - 65 Hz	45 - 65 Hz
Over voltage	690 V AC/DC	690 V AC/DC

protection

Power supply	2 x 1.5 LR03 battery	2 x 1.5 LR03 battery
--------------	----------------------	----------------------

Dimensions	255 x 70 x 28 mm	255 x 70 x 28 mm
------------	------------------	------------------

Weight	200g	200g
--------	------	------

*** END ***

This operating manual is subject to change without notice

UNI-TREND GROUP LIMITED

Rm 901, 9/F, Nanyang Plaza, 57 Hung To Road, Kwun Tong, Kowloon, Hong Kong
Tel : (852) 2950 9168 Fax : (852) 2950 9303
Email : info@uni-trend.com
http://www.uni-trend.com

Made: Uni-Trend Technology (China) Limited
Add: No 6, Gong Ye Bei 1st Road, Songshan Lake National High-Tech Industrial Development Zone, Dongguan City, Guangdong Province, China