



MODEL: GM280F

Film/ Coating Thickness Gauge Instruction Manual



Version: GM280F-EN-0

Contents

1. Before use notice

- Check-up------(01)
- Introduction -----(02)
- Features -----(02)
- Specification ----- (03)
- Diagram of the unit -----(04)
- LCD display -----(06)

2. Operation instructions

- Standard piece and Base material------(07)
- Connection between main unit and sensor------(08)
- Turn on the unit------(09)
- Instruments Calibration------(10)
- Imperial / Metric selection -----(14)
- Single measurement------(15)
- Continual measurement----- (17)
- DIF value measurement------(18)
- Data store -----(19)
- Data analysis------(20)

3. Other items

- Attentions----- (22)
- Maintenance and warranty------(25)

1. Before use

Check-up

Carefully unpack your kit and ensure that you have the following items. In case that any item is missing or if you find any mismatch or damage, promptly contact your dealer.

- Digital coating thickness tester main unit 1PCS
- Sensor 1PCS
- 1.5V AAA battery 3PCS
- English Instruction Manual 1PCS
- Standard sheet 6PCS
- Iron base material for calibration 1PCS
- PP Packing Box 1PCS

Introduction

Applying magnetic thickness measuring method, this unit can quickly and precisely measure the thickness of non-magnetic coating such as painting or electrodeposition on the iron magnetic substrate, and finds its wide application in the fields of manufacturing, metal processing, chemical industry and commercial inspection.

Features

- Providing visual readings and status of measurement on LCD
- Applying high sensitivity sensor for precise measurement
- With zero-point, two-points, and basic calibration methods to amend the system error quickly;
- With single, continuous and compensation measuring methods;
- Capable of saving, reviewing and deleting the data
- Able to delete the unreliable data in a measuring process as well as the data all saved in unit
- To save the maximum value, minimum value, average value, standard compensation value and measuring times
- Buzzer alert
- Unit switch between the metric and Britain system;
- Low battery indication
- Automatically turning off
- LCD backlight

Specifications

1.Measurement range:

Range	Resolution	Accuracy
0 to 1800 μ m	0.1 μ m/1 μ m	$\pm(3\%H+1\mu$ m)

Remark: H= Nominal transformation ratio

2.Condition of Objective material:

- Suitable for measure about non magnetic coating on magnetic conductor base material.
- The minimum curvature radius.
Convex=2mm Concave= 11mm
- Base sample diameter: 12mm
- Base substrate thickness: 0.5mm

3.Other Specification:

Technical parameter	Technical index
LCD display	3 1 / 2 display
Power supply	3*1.5V AAA alkaline battery
Operation current	Around 25mA
Battery life	Continuously 20 hour
Auto off	1 min.
LCD backlight function	7 second
Operation temperature	0 to 40°C
Operation humidity	10 to 95%RH
Low battery indication	2.8V \pm 0.2V
Product size	72x35x145mm
Weight	246.1g (without battery)

Diagram of the unit

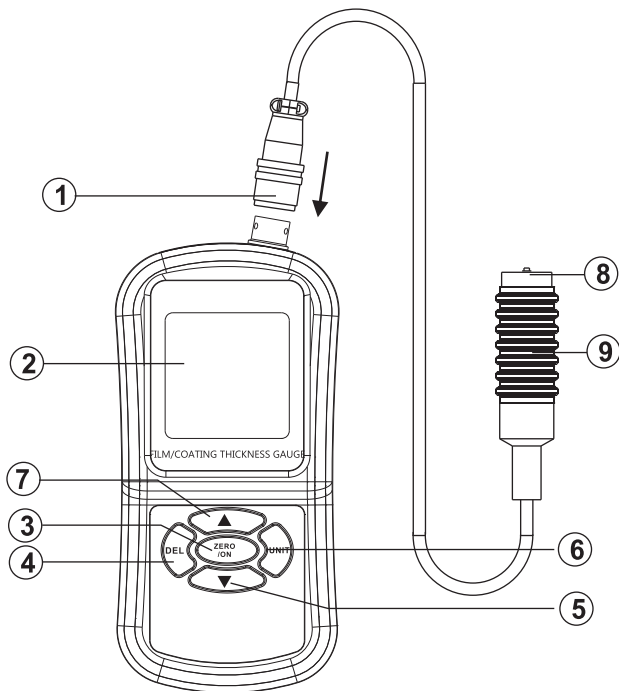

1. Connector (With direction indicator)

2. LCD display

3.  : Power on/ Set zero

4.  : Data delete key

5.  : Menu (single measure SNG, Continuously measure CTN, Average measure Average, Maximum measure MAX) pagedown and basic calibration key

6.  : Unit convert between Metric and Imperic

7.  : Menu (single measure SNG, Continuously measure CTN, Average measure AVG, Maximum measure MAX) pageup and basic calibration key.

8. Sensor

9. Rubber cover



Note:

Above key function descriptions just are simply introductions, for details please read operation instructions part in this manual.

LCD display



1. Battery power symbol, shows the battery power
2. Measure value dynamic bar
3. **Fe** : Ferrous measuring
4. Measurement value display area
5. Measurement mode, Data analysis indication
6. **M** : Memory record status
7. μmil : Imperial/ Metric unit change
(1mil= 0.0254mm=25.4 μm)
8. Recorded data display
9. Measuring range symbol
10. : Backlight indication, the backlight will be off after no further operation for 7seconds.

2.Operation instructions

Substrate ad standard piece

- Standard piece:
 - a. All the sample with a known thickness could be used as a standard calibration piece and in short referred to as standard piece.
 - b. The coated standard piece
An even firmly-coated standard piece with a known thickness could be used as a Standard Piece too, and in terms of the application of this product, the coating must be non-magnetic.
- Substrate:
 - a. The standard substrate's roughness and magnetism, must be close to those of the material to be measure.
To identify the suitability of the substrate, compare the outputs from the standard piece with the material to be measured.
 - b. If the thickness of the material is in the range of the regulated, two methods could be selected to calibrate.
 - 1). To calibrate a metal Standard Piece that with same thickness as the material to be measured.
 - 2). use a similar magnetic and electricity standard metal gasket piece which have enough thickness for calibration, be sure that there is not spacing between substrates.
 - c. If the curvature of the material is too big to be calibrated on the flat surface, please ensure that the coated standard pieces curvature has the same thickness as the material to be measured.

Connect between handle sub- unit and main unit

Pay attention to indicator direction

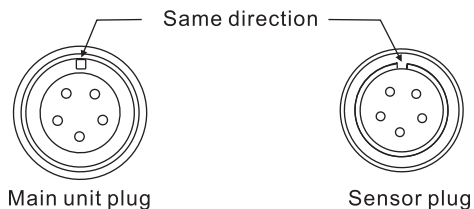

Plug in and Plug-out method:



When plug in, plug-in the sensor plug into the main unit's sensor socket with same direction. Press until the sensor plug produces a locking sound to ensure the connection was in a locking status.

When plug out, push up the sensor plug's metal cover to disable the locking status. Then pull out the sensor plug.

Turn on the unit

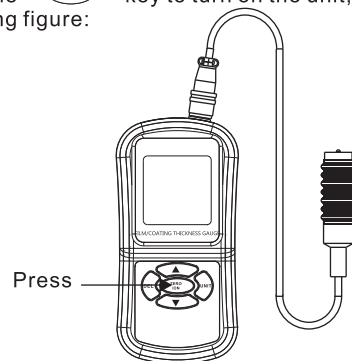
1. Pull up the snap of the battery door to open it and insert the battery included in the package, then close the door and lock it up.
2. Press the “” key to turn on the unit, as shown in following figure:



3. After the entire screen displays for 1 second, the default state is single test mode ,if the LCD screen displays the symbol  or  , please promptly replace the battery, as shown in following figure:

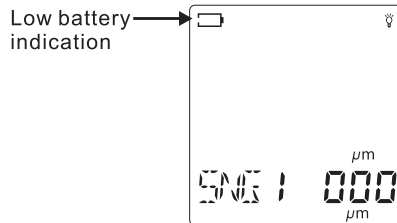

Calibration

To ensure the precise test result, please calibrate the instrument at the test scene. The instrument has three different calibrations methods: zero point calibration, two point calibration, and basic calibration.

○ Zero point calibration:

- a. Take a measurement on a standard substrate or on an uncoated substrate. LCD display a data, for example, $0.3 \mu\text{m}$, like the following picture:

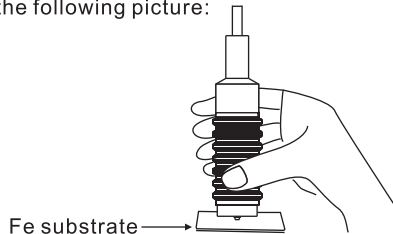

- b. Do not lift the detect tip and press the **ZERO /ON** key, the buzzer will sound, that signal indicated the zero point calibration is completed. LCD displays as shown below:

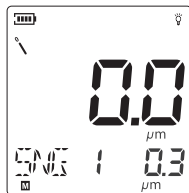

- c. Repeat step a and b to make basic measure value less than $1 \mu\text{m}$, this can improve measurement precision.

○ Two point calibration:

- a. Calibrate zero point first.
- b. take a measurement on the standard piece which thickness close to the target piece. (like $1000 \mu\text{m}$), if the LCD display $1008 \mu\text{m}$, like the following picture:

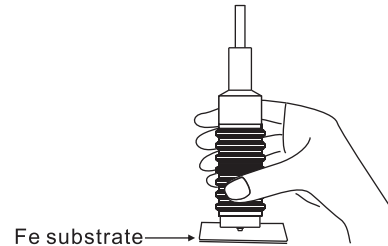

- c. Do not lift the detect tip and press the " \blacktriangle " and " \blacktriangledown " key to adjust the reading as same with the standard piece, after these calibration is complete, the instrument is ready to use. LCD displayed like the following picture:

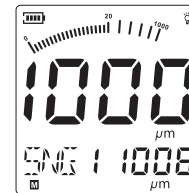

To ensure a precise two point calibration, repeat step b and c to improve measurement precision and reduce incidental error.

○ Basic calibration:

It is necessary to change the basic calibration under the following conditions:

- the top of the detect head is worn off
- after the detect head is maintained
- Special use
- the product has not been used or calibrated for a long time

- a. Prepare six standard pieces, which the thickness at 45~55, 95~105, 220~280, 450~550, 900~1050, 1900~1999, unit: μm .
- b. Hold the “▲” key and press the “ZERO/ON” key to turn on the unit, LCD displayed as following:

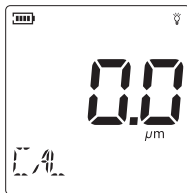

When appear the value 0.0um, you can take zero calibration to iron basic.

- c. Choose a standard piece at thickness between 45-50, when obtain a reading for example 48.0, LCD displays as following:

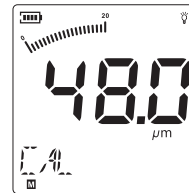

Press “▲” and “▼” key to adjust the display value to be equals with the standard piece's thickness, and then place the next standard piece on the iron basic to calibrate.

- d. Repeat the above steps until the last standard piece is calibrated, after the unit auto power off and the new calibrated value have been saved in the memory. Turn on the unit, and it is now ready to measurement.

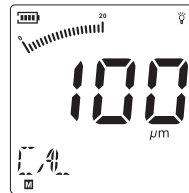

Unit selection

Press “” key to turn on the unit, and then press UP/DOWN key to change the mode, when LCD display UNT, that means enter the unit selection mode.

The default unit is μm , LCD displays as shown below:

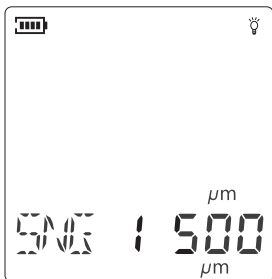

Press “” key, you can select your desired unit on μm to mil, LCD displays as shown below:

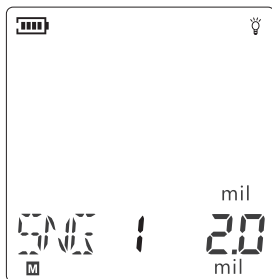

Single measurement

Prepared target piece you want to test.

- Press “” key to turn on the unit, the default test mode is single test mode, LCD displays as shown below:

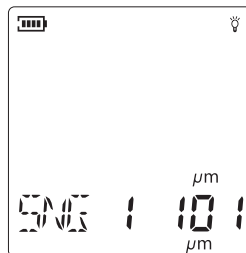

- Contact detect head with the test surface vertically and press the detect head lightly, LCD displays a value, for example, 109 μm , and buzzer sounded at this time, LCD displays as shown below:

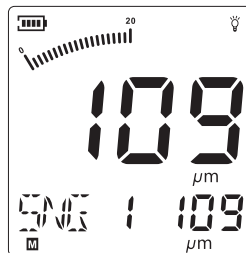

- When the second measurement is finished, SNG counter will automatic upgrade to 2. The maximum SNG counter is 15.

When it is full, it will stop to increase the number.

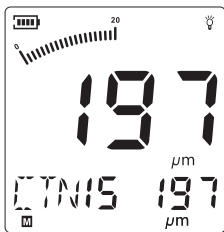

- Every time detect head contact the test surface vertically, an reading will be generated with a beep of buzzer. For another measurement, lift the detect head, and repeat the operation above.

⚠ Caution:

If the detect head gets the iron basic too closed when you open the tester to self- check, LCD will display ERR.

Continuous measurement

- Turn on the tester, and press "▼"/"▲" key to select the test mode, when LCD displays CTN, that means Continuous measurement mode. LCD displays as following picture:

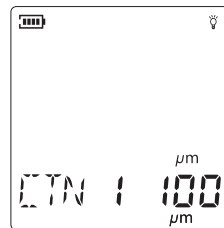

- Place the detect head to the target piece you want to measure, and then press the detect head lightly to measure, the buzzer will not sound during the measurement, LCD will display the measure result continuously, the last measure value will be saved in the test automatically, the quantity of the data are also be memorized, LCD display CTN1 at the same time, LCD displays as following picture(The max memory is up to 15th, including SNG memory):

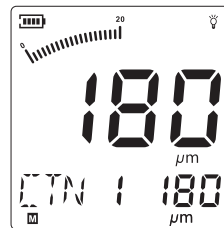

Standard Deviation measurement

- Turn on the tester, and press "▼"/"▲" key to change the test mode, when LCD display "DIF", that mean the tester turn into standard deviation measurement mode.

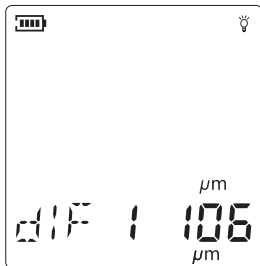

- Place the sensor head to the target piece you want to measure, then press the detect head lightly to measure, the buzzer beeps, LCD will display the value of the difference between the last reading and the current reading, LCD displays as shown below:

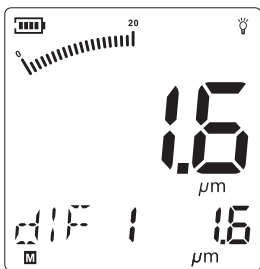

Data record/ recall and delete

1. Record:
The measurement result will be saved automatically after every measuring and the measurement quantity will be increase one by one, the max number is 15.
2. Data recall:
Press "▲" and "▼" key to review the measurement values when the measurement number is flashing.
3. Delete:
 - a. Delete the current data: when you do not want to delete one of the stored data, you can press the "▼" key to go back to the last one when the measurement number is flashing, and then take another measurement to replace the stored data.
 - b. Delete all the data: you can delete all data by pressing the "DEL" key for 2 second when the measurement quantity is flashing.

Data analysis

The tester also provide data analyse function after have measured several groups of data, press “▼” / “▲” key to change mode, LCD will display average value (AVG), MAX, MIN, Standard Deviation(dFR), data number(NO), LCD displays as following picture:

Display average value (AVG):

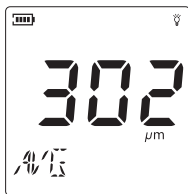

Display Maximum value (MAX):

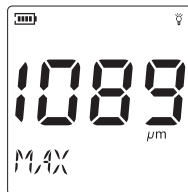

Display Minimum value (MIN):

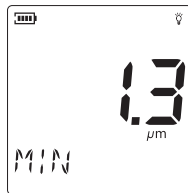

Display Standard warp (dFR):

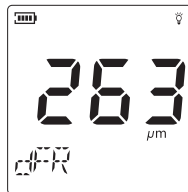

Display Data Number (NO):

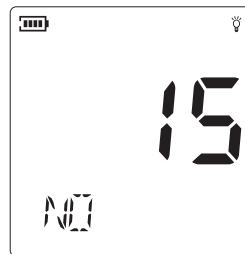

Caution:

- when the measurement number is flashing, please press “” key to stop it. And press “▼”/“▲” key to change mode.
- The displayed value in the operation instruction is merely examples to illustrate, please refer to the value obtained in your practice.
- The tester will power off automatically in 1 min. If no further operation happens.

3. Other items

Attentions

1. Factors which affect the measurement precision and some instruction:

a. Magnetism of substrate metal:

The magnetism rule varies with the magnetism of a specific substrate metal (in application there is only a slight change of low carbon steel magnetism), to avoid the interference resulting from the heat treatment and cold process of the metal, a standard piece to be coated can also be used to calibrate.

b. Thickness of substrate metal:

Every instrument is subject to a critical thickness of a certain substrate metal which allows the measurement to be taken when the thickness is larger than the critical.

This unit's critical thickness (minimum substrate thickness) is 0.5mm.

c. Verge effect:

The unit is sensitive to the steep change on the surface of the target piece. So the output obtained near the verge or inner angle of the piece is not reliable.

d. Curvature:

The curvature of the target piece may affect the measurement result. This effect will be increased as the curvature's radius reduced.

e. Roughness degree of the surface:

The roughness degree of substrate metal and coating may affect the measurement. The bigger the roughness degree is, the bigger the effect is. Rough surface will cause system error and incidental error.

You should increase the measurement number at different place to reduce incidental error. If the substrate metal is rough, you must adjust ZERO point on the substrate metal which is not coated and has similar roughness with the target one; or you can use impregnant which can not erode the substrate metal to dissolve the coating, and then to adjust the ZERO point.

f. Magnetic field:

The strong magnetic generated from the surrounding electronics will severely affect the measurement precision.

g. Adhesive layer:

The unit is sensitive to the attachment between the test head and the coating, so you must clear the layer to make sure the test head contact the coating directly.

h. the detect head's pressure:

The pressure on the target piece can affect the measurement value, so the unit uses spring to generate a steady pressure.

i. Detect head's angle:

The angle of the test head affects the measurement. You must be sure the detect head to be contact the target piece is at a right angle.

j. the target piece's distortion:

The detect head can make the target piece of soft coating distort, if the distortion is too big, the measurement value is not correct.

2. Attentions in operation:

a. The property of substrate metal

The metal magnetism and surface roughness of the standard piece should similar with the target piece.

b. the thickness of the substrate:

Check whether the substrate's thickness is less than the critical thickness 0.5mm.

c. verge effect:

Do not measure at the locations where there are steep shape change of the measured, i.e. Verge, hole or inner corner and so on.

d. Curvature: Do not measure at the distorted surface.

e. The readings:

Because the readings may not be identical all the time, so you should several measurements at the same area. The local difference of the coating also requests to measure several times at the specified area especially rough surface.

f. Cleanness of surface:

You should clear all the adhesive layer on the surface like dust, grease, rust etc. Before taking measurement, but do not remove any coating.

3. About the measurement reading:

a. As per statistics, single value is not reliable enough, so all the output readings are average value of multiple measurements that is carried out by the unit within hundreds of milliseconds.

b. To ensure more precision reading, you can measure several times, and then delete the max error one, at last use analysis function to get five statistical data: average value (AVG), MAX, MIN, standard warp (dFR), data number (NO).

c. According to the international standard, the final measure result can be expressed as the following formula:

$$CH=A\pm 2D$$

CH---the thickness of the coating

A----the average value of the measure data (AVG)

D-----standard warp (dFR)

Maintenance and warranty

Maintenance:

1. Replacement and upkeep of battery:
 - a. After power on, if an icon  appears on the LCD, you need to replace the battery immediately, for details please refer to figures and contents on page 9 of this manual.
 - b. Remove the battery from the unit if it is not required for extended periods of time in order to avoid damage to the battery compartment and the erosion resulting from a battery leakage.
2. Do not store or use the unit in following circumstances:
 - a. Splashes of water or high levels of dust.
 - b. Air of high salt or sulphur content.
 - c. Air mixed with other gases or contents.
 - d. High temperature or humidity (above 50°C, 90%), or direct sunlight.
3. Do not disassemble the unit or attempt any internal alterations.
4. Never use alcohol or diluents to clean the housing for doing that will especially erode the LCD surface; just clean the unit lightly as needed with little clean water.

Warranty:

1. About relative warranties please read warranty card.
2. We disclaim any liability due to: client's transportation damages; incorrect use or operation; manipulation, alterations or repair attempts; without warranty card, invoice.



Specific Declarations:

Our company shall hold no any responsibility resulting from using output from this product as an direct or indirect evidence.

We reserves the right to modify product design and specification without notice.