

MASTECH® MS2010A

AC Leakage Current Clamp Meter Instruction Manual

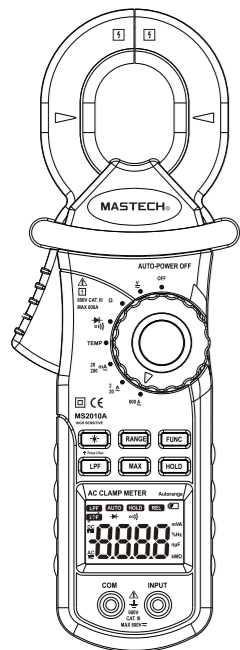

MASTECH®

1. Safety information

The meter is a handheld and battery operated Digital AC Clamp Meter with multi function. This clamp meter has been designed to meet IEC 61010-1 and CAT III over Voltage category.

⚠ Warning

To avoid possible electric shock or personal injury and possible damage to the meter or the equipment under test, you are must be adhere to the following rules.

1-1.Safety cautions

- User must be read the operating instructions thoroughly and completely before operating your meter. Pay particular attention to WARNING, which will inform you of potentially dangerous procedures.
- Do not apply more than the rated voltage ,of marked on the meter, between the "INPUT" terminal and "COM" terminal.
- Do not expose the instrument to direct sunlight, extreme temperature and moisture or dew full.
- You always are careful when working with voltage above 60V DC or 30V AC rms.
- Keep fingers behind the clamp barrier while measuring current..
- Always inspect the test lead for damaged insulation or exposed metal.

1-2. Symbols

Note international Electrical Symbol.

	Dangerous Voltage		Ground
	AC (Alternating current)		Warning see explain in manual
	DC (Direct Current)		Double insulation

01

MASTECH®

2. Meter illustration

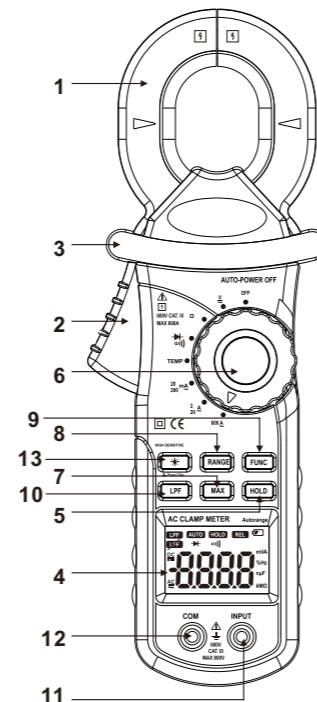

Panel description

1. Clamp jaw : it is as current transformer (CT) when measuring current flowing through the conductor .
2. Trigger
3. Clamp Barrier:
4. LCD display
5. "HOLD" button
When push this button, the display will keep the last reading. Once push again, the Meter will return the normal mode.
6. Knob: it is rotary switch for select function.
7. "MAX" button
8. "RANGE" button
9. "FUNC" button
10. "LPF" button
11. "INPUT" terminal
12. "COM" terminal
13. "*" Back Light push button

02

MASTECH®

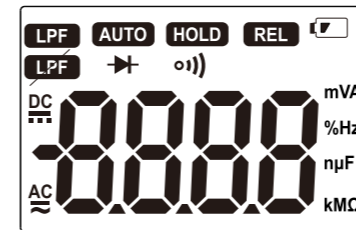

LCD display

- Alternating current
- Directive current
- Diode
- Continuity
- Auto ranging mode
- Maximum value measurement mode
- Low pass filter is act
- Low pass filter is non act
- Data hold mode
- Low battery

03

MASTECH®

3. Specification

3-1. General feature

- Auto ranging Digital Clamp Meter. But the meter may select manual Function mode by "RANGE" button.
- 3 1/2 digit (200 count) LCD display
- Over load indication: "OL" symbol will displayed on the LCD.
- Jaw opening capability: 32mm
- Low battery indication: battery symbol is appears on the LCD.
- Auto power OFF: If the meter is idle for more than 15 minutes, the meter automatically turns the power off.
- Sampling rate: 2 times/s
- Power supply: 1.5V battery (AAA type) x 3pcs.
- Operating temperature & Humidity: 0°C to 40°C; <80%
- Storage temperature & Humidity: -10°C to 50°C; <70%RH
- Dimension (L x W x H) & Wight : 260 x 92 x 55mm; Approx. 400g

3-2. Electrical Specification

[1] AC Current

Range	Resolution	Accuracy	
20mA	0.01mA	(50 ~ 60Hz)	(30~50Hz,60~10KHz)
200mA	0.1mA		
2A	1mA	±(1%rdg+8dgt)	±(3%rdg+10dgt)
20A	10mA		
200A	100mA		
600A	1A	±(1.5%rdg+3dgt)	

04

MASTECH®

[2] AC Voltage

Range	Resolution	Accuracy	
200mV	0.1mV	(50 ~ 60Hz)	(30~50Hz,60~10KHz)
2V	1mV		
20V	10mV	±(0.8%rdg+5dgt)	±(2%rdg+10dgt)
200V	0.1V		
600V	1V		

- Input impedance; 10MΩ

[3] DC Voltage

Range	Resolution	Accuracy	Input impedance
200mV	0.1mV	±(0.7%rdg+3dgt)	10MΩ
2V	1mV		
20V	10mV		
200V	0.1V		
600V	1V		

[4] Resistance

Range	Resolution	Accuracy	Over load protection
200Ω	0.1Ω	±(1%rdg+2dgt)	250V DC or AC rms (by PTC protection circuit)
2KΩ	1Ω		
20KΩ	10Ω		
200KΩ	0.1KΩ		
2MΩ	1KΩ		
20MΩ	10KΩ	±(2%rdg+5dgt)	

[5] Temperature

Range	Resolution	Accuracy	
-20°C to 1000°C	1°C	-20°C to 0°C	±(5.0%rdg+5dgt)
		0°C to 400°C	±(1.5%rdg+3dgt)
		400°C to 1000°C	±(3.0%rdg+3dgt)
-4°F to 1832°F	1°F	-4°F to 32°F	±(5.0%rdg+5dgt)
		32°F to 752°F	±(1.5%rdg+3dgt)
		752°F to 1832°F	±(3.0%rdg+3dgt)

05

MASTECH®

[6] Diode check

Test current : 1mA

[7] Continuity

If the resistance under testing circuit less than 50Ω, buzzer will sound.

4. Operating instruction

4-1 LPF usage

The meter have Low- Pass-Filter to reduce the influence of high frequency noise above 1KHz(3db). This LPF feature is available in all AC Voltage or AC Current measurement mode. The "LPF" button is act as ON/OFF switch for LPF circuit connection. When LPF is activated, Most of noise above 1KHz will decay greatly. So we can obtain more stable and accurate readings on low frequency response.

4-2 Data HOLD

The push key is used to maintain the measurement data unchanging. Press "HOLD" push key to inter and exit the hold mode in any mode. That act with trigger. The meter will resume the normal measurement mode by pressing the key again.

4-3 Range switching

"RANGE" button is the auto/manual measurement push key that act with trigger. The default is auto measurement when power on. Press this key once, will switch to manual measurement mode, and then press once again, will switch to auto measurement mode.

4-4 Function switching

"FUNC" key is used as the function selection key that acts with trigger. Use the key as switch of DC/AC, Diode/ Continuity and °C/°F.

06

MASTECH®

4-5 Maximum value hold

"MAX" key is act with trigger. Press this key once, the maximum value is holding(will Displays "MAX" symbol on the LCD), and the press once again, will switch to normal Measurement mode. After pressing the key, A/D will keep working, and the display value are always up dated and keep the maximum value.

4-6 Back Light

"☼" Push key is used control Black Light. When press this key and held more than 2sec, will enable Back Light for 15secs. Press the key again within 15secs, back light will disable.

4-7 Sleep mode (Auto power OFF)

If the meter is idle for more than 15minutes, the meter automatically turns the power off. In this sleep mode, the meter is save battery energy. In the sleep mode, the meter may be turns normal operating mode by "RANGE", "MAX", "☼" Key and rotary switch.

There are two ways to disable the sleep mode as following:

- (1) In the auto power off state , you are pushing "HOLD" key.
- (2) Push and held "HOLD" key, turn on power by rotary switch at the same time.

5. Measurement operating

5-1 AC Current measurement

1. Set the rotary switch to the desired "A~" position.
2. Press the clamp trigger to open jaw and to clamp one conductor only, making Sure that the jaw is firmly closed around the conductor.
3. Set the conductor in that flow the measured current to centre position of jaw as far as Possible. In this time, measurement accuracy is best.
4. Read current value on the LCD display.

07

MASTECH®

Not: (1) Use the Low Pass Filter by pushing "LPF" button if necessary.

- (2) When measurement the current of transmission line, must be clamp one line only between the two line .

5-2 Leakage current measurement

This meter can measure the leakage current on the one-phase or three-phase circuit equipment as well as the conductor in that flow the leakage current.

1. Set the rotary switch to the 20mA~ range.
2. Clamp the conductor in that flow the leakage current, and the read the leakage 0current value on the LCD display.

5-3 DC/AC Voltage measurement

1. Set the rotary switch to the "V" position. The DC mode is default mode. To switch to the AC measure mode must be press once time the "FUNC" button.
2. Insert the red test lead in to the "INPUT" terminal and the black test lead into the "COM" terminal.
3. Connect the test lead across with the object being measured. The measured value will be show on the LCD display.

Note:

When DC or AC voltage measurement has been completed, disconnect the connection between the test lead and circuit under test.

5-4 Resistance measurement

1. Set the rotary switch to the "Ω" position.
2. Insert the red test lead into the "INPUT" terminal and black test lead into the "COM" terminal.
3. Connect the test lead across with the object being measured. The measured value will be show on LCD display.

Note:

- The test lead can add 0.1Ω to 0.2Ω of error to resistance measurement.
- To obtain precision reading in low-resistance measurement.

08

MASTECH®

that is the range of 200Ω, short the input terminal with the test lead probe, and then read out the contact resistance of test lead. After measuring you can subtract the readied contact resistance value from the reading value.

- For high resistance measurement (>10MΩ), it is normal taking several seconds to obtain stable reading.
- If The LCD display "OL" symbol .it is indicating open circuit for the tested resistor or the resistance value of resistor is higher than the maximum range of the meter.

5-5 Diode check

The diode check function used to check diode, transistor and other semiconductor device.

In the diode testing, the meter sends a current through the semiconductor junction, and then measure the voltage drop across the junction. A good silicon junction will drop between 0.5V to 0.8V.

1. Set the rotary switch to the "▶|○|)" position.
2. Insert the red test lead into the "INPUT" terminal and the black test lead into the "COM" Terminal.
3. For forward voltage drop reading on any semiconductor component, place the red test lead on the component anode and place the black test lead on the component cathode. The measured forward drop voltage will show on the LCD display.
4. Reverse the test lead and measure the voltage across the diode again.
 - If diode is good, the display shows "OL".
 - If diode is shorted, the display shows "0" (zero) in both direction.
 - If display shows "OL" in direction, the diode is open.

5-6 Continuity check

1. Set the rotary switch to the "▶|○|)" position.
2. Press the "FUNC" push button to switch into continuity check mode.
3. Insert the red test lead to the "INPUT" terminal, and then black test lead to the "COM" terminal.
4. Connect the test lead across with the object being measured. If the resistance of a circuit under test is less than 30Ω, the buzzer will sound.

09

MASTECH®

5-7 Temperature measurement

Note:

- MS3202 Multi-Function Socket is used as temperature adapter.
 - Use K-type thermocouple probe.
1. Set the rotary switch to the "TEMP" position.
 2. In this time, LCD will display the environment temperature.
 3. Insert the MS3202 temperature adapter to the "INPUT" and "COM" terminal , and then Insert the K-type thermocouple probe to the MS3203 temperature adapter according to its polarity.
 4. To change the temperature physical unite(°C or °F) , you can press the "FUNC" push button.

6. Maintenance

6-1 Replacing the Battery

When meter display low battery indicator(symbol) on the LCD, you must be replace the battery to maintain normal operation.

- (1) Disconnect and remove all test probes from any live source and meter.
- (2) Open the battery cover on the bottom case by screwdriver.
- (3) Remove old battery and snap new one into the battery holder.

6-2 Fuse replacement

Replacing the defective fuse should done according to 6-1section procedure.

6-3 Cleaning and Decontamination

The meter can be cleaned with soft clean cloth to remove any oil, grease or grim. Do not use the liquid solvent or detergent.

7. USB interface with a personal computer(PC)

7-1 Connect the Meter to PC with USB cable

7-2 Installation of application software

10



00-05-1905